

## ROTOR LOCK SJ-180/85

A rotor lock is a hydraulic, mechanical or electrically powered safety mechanism used during maintenance or emergencies. An active rotor lock prevents the rotation of the rotor blades of a wind turbine.

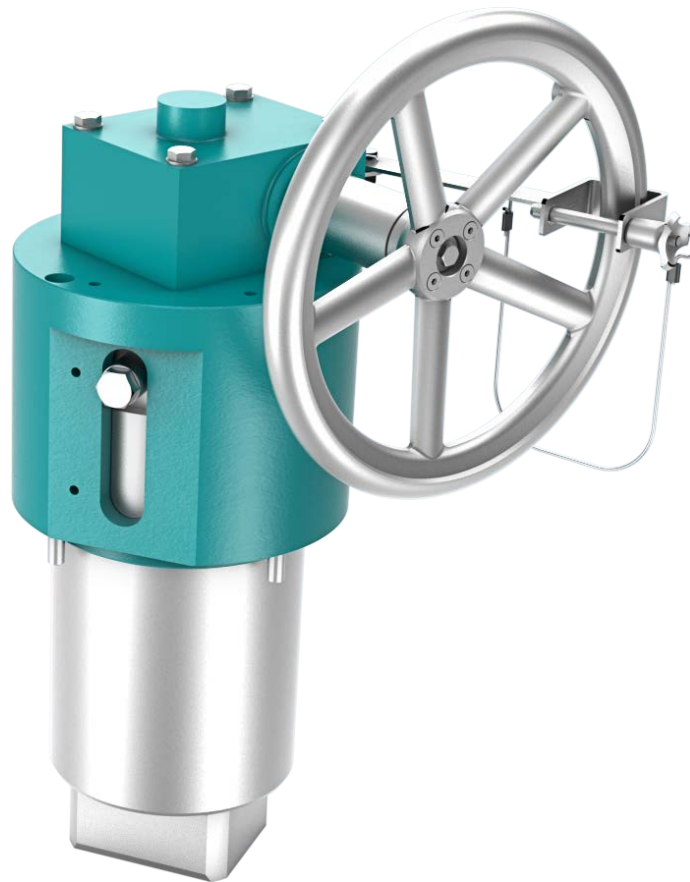

### FEATURES

- Mechanical powered by hand
- Compact and maintenance-free design
- Additional mechanical block
- Easy apply of lock pin due to conical shaft-end
- Standard or offshore design
- Offshore protection as per ENI 2944
- Screw jack to increase force
- Greasing via grease nipple

### SPECIFICATIONS

	VALUE	UNIT
ARTICLE NUMBER	20-1336	-
WEIGHT	± 125	Kg
CAPACITY	25	N
STROKE	85	mm
RATIO	6:1	-
TR SCREW	30x6	-
MAXIMUM STROKE	85	mm
TEMPERATURE RANGE	-40 / +70	°C
LOCK PIN MATERIAL	34CrNiMo6+Qt	-

## GENERAL DIMENSIONS

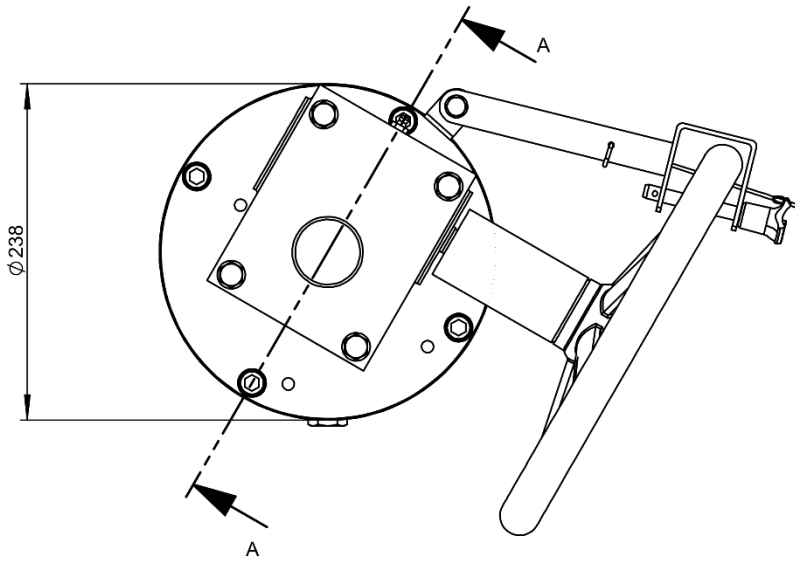

**TOP VIEW**  
 SCALE 1:5

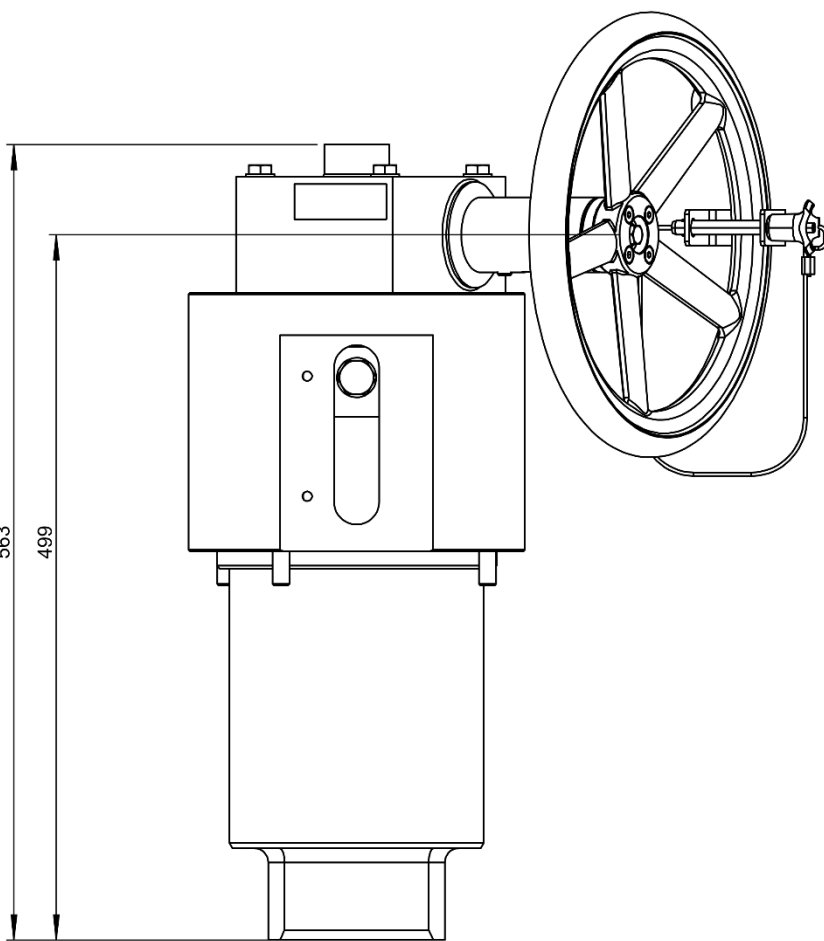

**FRONT VIEW**  
 SCALE 1:5

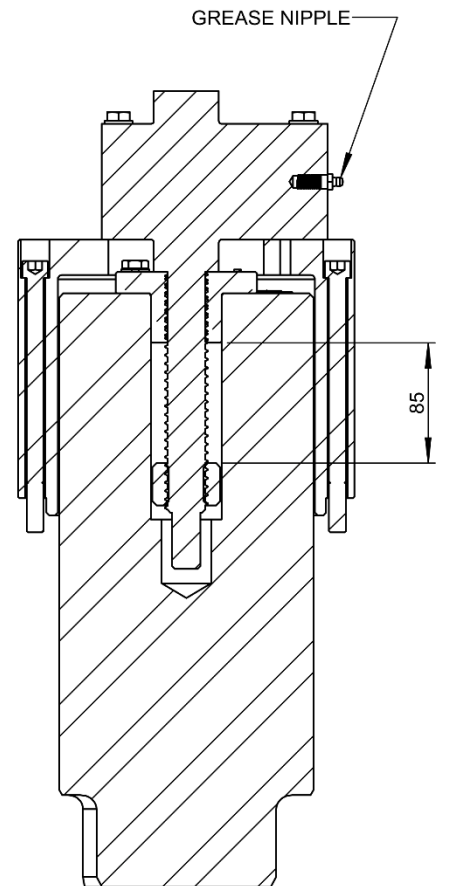

**SECTION A-A**  
 SCALE 1:5

Trebu reserves the rights of modification without prior notification