

HPU ROTOR BRAKES

A hydraulic power unit converts mechanical- to hydraulic energy to power industrial equipment. A HPU uses an electric motor driving a hydraulic pump to pressurizes fluid. The pressurized fluid is applied in mechanical equipment, such as braking systems delivered by Trebu.

FEATURES

- HPU controls Trebu rotor brakes
- Collaborating with multiple consumers & components
- Variable working pressures possible per specification
- Easy installation with quick connectors
- Efficient cooling reducing heat production
- Lower noise and vibration levels than conventional HPU's
- Operate rotor lock manually by ball valve
- Safety features to prevent accidental rotor lock operation
- Easy PLC connectability and control
- Oil in tank level-eye display
- Fast braking and retraction time for reliable operation
- Integrated handpump

OPTIONS

- Switches & sensors
- Connectors & cables
- Filter elements
- Steel manifold

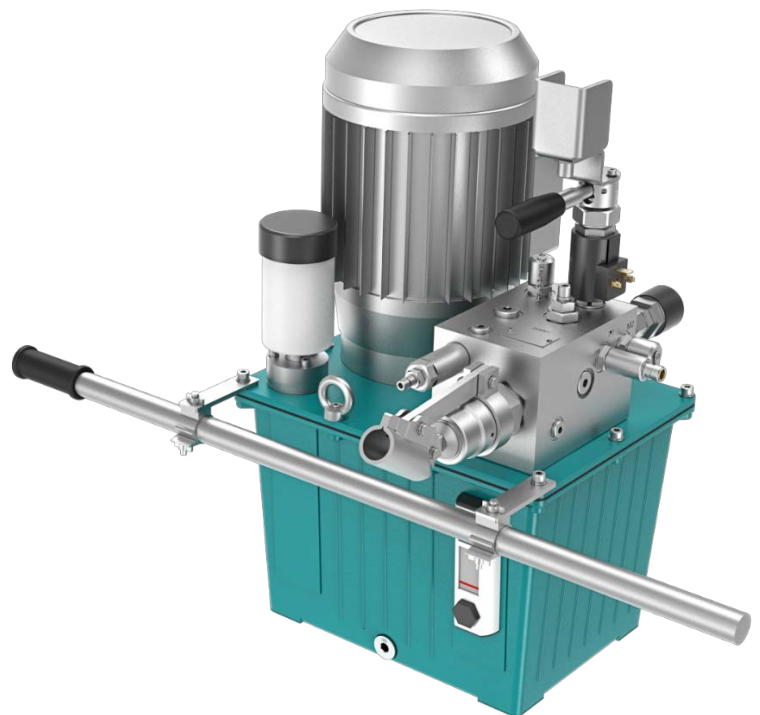

SPECIFICATIONS	VALUE	UNIT
ARTICLE NUMBER	10-1108	-
WEIGHT (WITH OIL)	40	Kg
NOMINAL PRESSURE	19	MPa
MAXIMUM PRESSURE	21	MPa
PUMP CAPACITY (AT 1500 RPM)	4,6	L / min
MOTOR TYPE	Asynchronous IE2	
MOTOR POWER	1,5	kW
MOTOR VOLTAGE	230 / 400	V
MOTOR FREQUENCY	50 / 60	Hz

SPECIFICATIONS	VALUE	UNIT
MOTOR SPEED	1500	rpm
MOTOR PHASES	3	-
TANK CAPACITY	7,5	L
HAND PUMP CAPACITY	21,3	cc / stroke
HYDRAULIC OIL	ISO-V6 46	-
TEMPERATURE RANGE	-40 / +70	°C
CORROSIVITY CLASS	C3	-
PAINT COLOUR	5021	RAL
HYDRAULIC SCHEME	OH21020.1	-

GENERAL DIMENSIONS

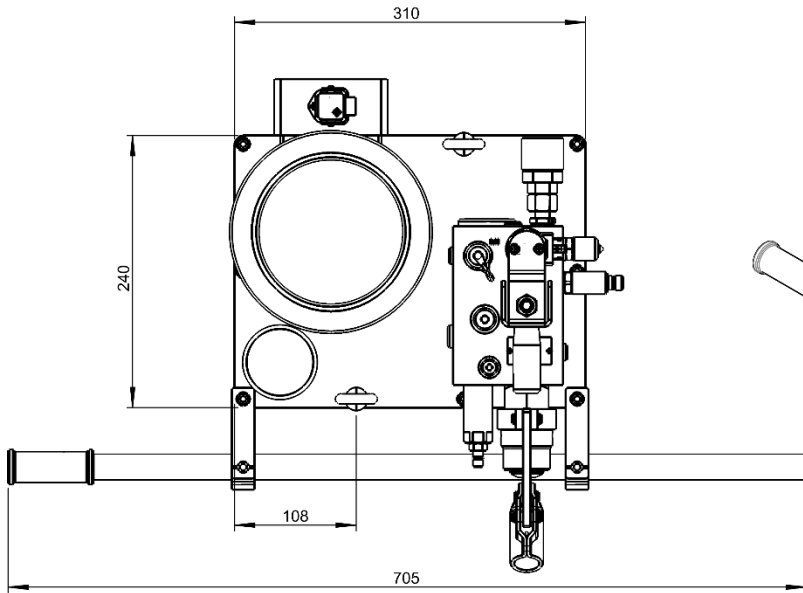

TOP VIEW
 SCALE 1:5

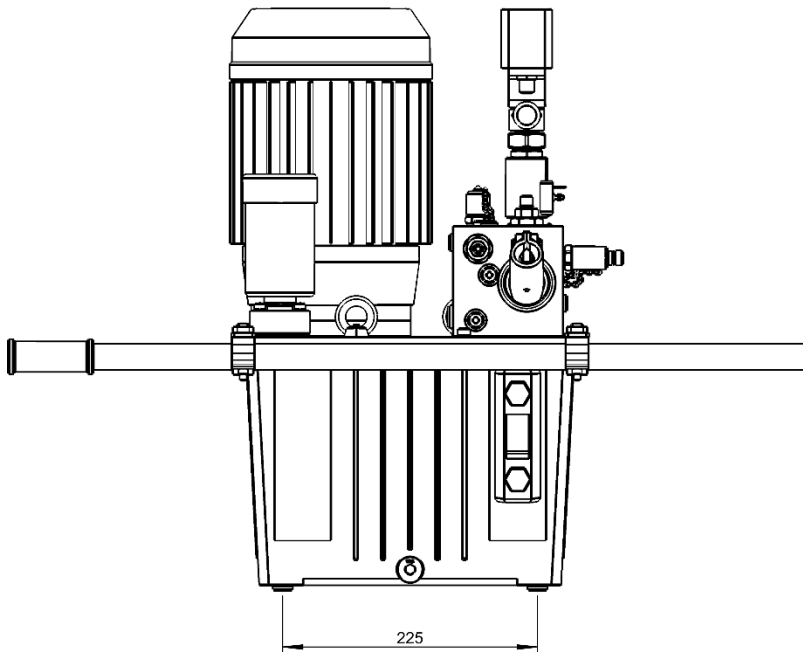
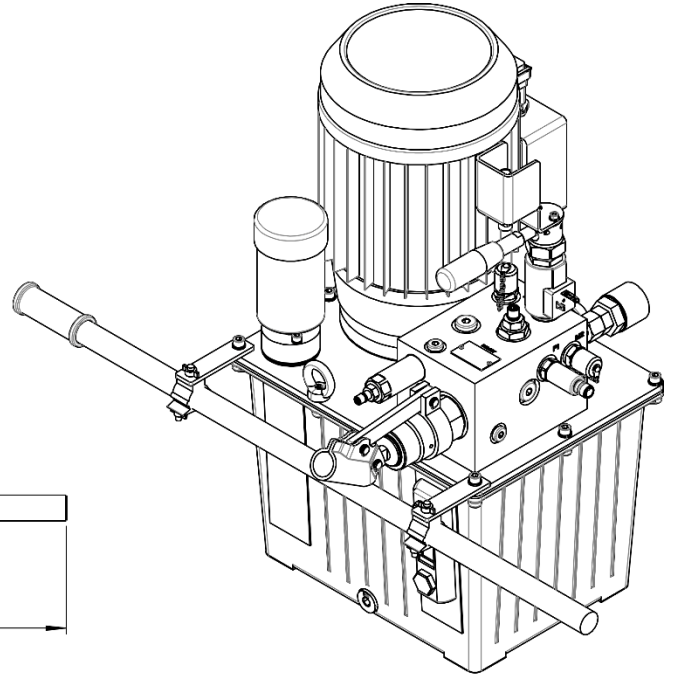

FRONT VIEW
 SCALE 1:5

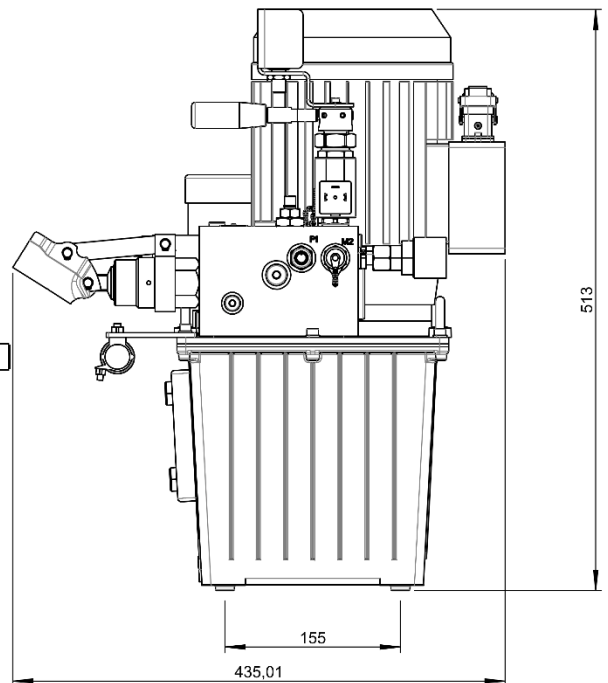

RIGHT VIEW
 SCALE 1:5

Trebu reserves the rights of modification without prior notification