

## AB-1-110-100 YAW BRAKE

Yaw brakes are mounted at the nacelle base frame to control the position of the nacelle during operation, as it rotates with the changing wind direction to maximize power and efficiency.

### DATASHEET SPECIFICATION

<b>ARTICLE NUMBER</b>	20-1002
<b>MAX. PRESSURE</b>	21 MPa
<b>MAX. CLAMPING FORCE</b>	199,5 kN
<b>MAX. BRAKING FORCE</b>	79,8 kN
<b>FRICTION COEFFICIENT <math>\mu</math></b>	0,4 [-]
<b>DISC THICKNESS</b>	Not applicable
<b>WEIGHT</b>	18 kg
<b>BRAKE HOUSE MATERIAL</b>	EN-GJS-500-7
<b>TEMPERATURE RANGE</b>	-40 / +70 °C
<b>PISTON DIAMETER</b>	110 mm
<b>SINGLE PISTON SURFACE AREA</b>	95,0 cm <sup>2</sup>
<b>LINING TYPE</b>	Organic TR146
<b>LINING DIMENSIONS</b>	72 x 145 mm
<b>LINING THICKNESS</b>	35 mm
<b>FRICTION MATERIAL THICKNESS</b>	10 mm
<b>MAX. PERMITTED LINING WEAR</b>	8 mm

### FEATURES

- Double high pressure seal, redundancy
- Grooved brake pads for redirecting fine dust & contamination
- Drain ports for oil leakage, preventing pads contamination
- Brake pads with electric wear indicators

### CALCULATION LEGENDA

- F<sub>b</sub>** = Braking Force
- F<sub>c</sub>** = Clamping Force
- $\mu$**  = Friction Coefficient
- M<sub>b</sub>** = braking Torque
- z** = Number of Brakes
- D<sub>av</sub>** = Effective Diameter of brake

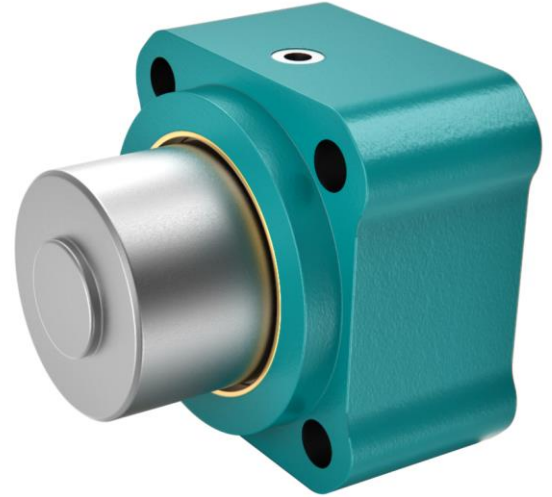

### BRAKING FORCE GRAPH

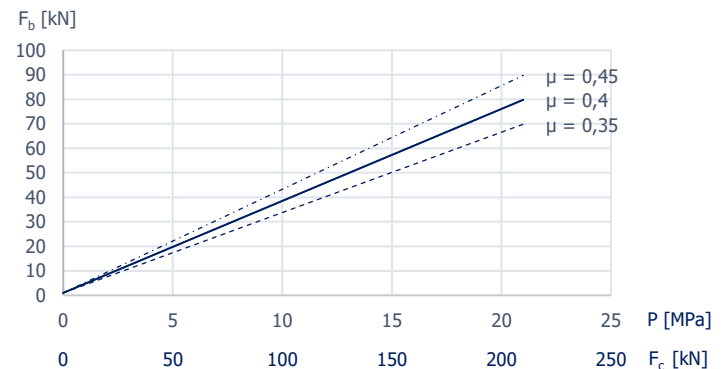

### BRAKE FORCE CALCULATION

$$F_b = 1 \cdot F_c \cdot \mu^*$$

$$F_c = A \cdot P \cdot 10 \text{ [N]}$$

$$M_b = z \cdot F_b \cdot \frac{D_{av}}{2}$$

\*External factors have not been taken into consideration

## GENERAL ARRANGEMENTS

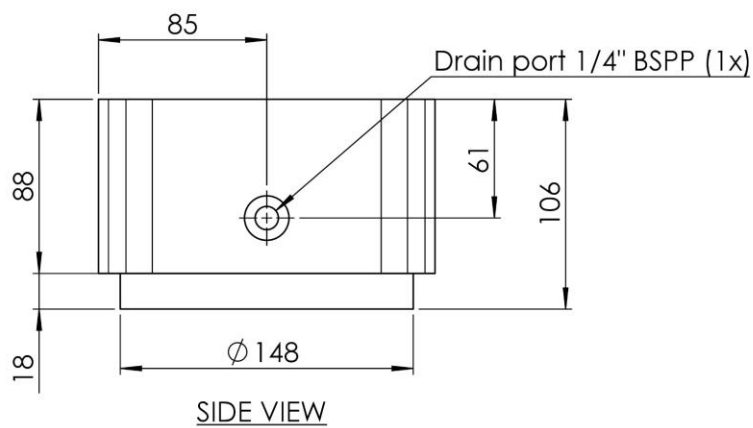
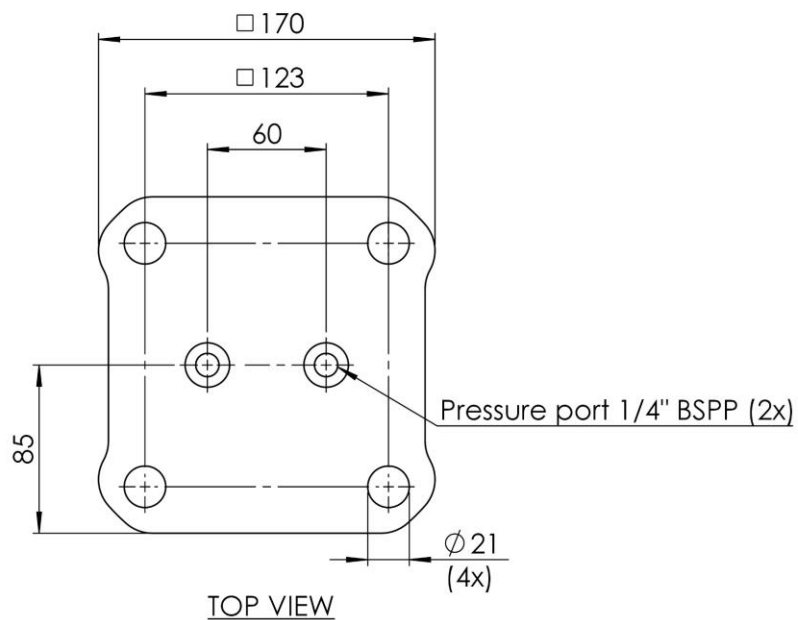

Trebu reserves the rights to modification without prior notification