

AB-2-90-103 ROTOR BRAKE

Active brakes are a complement to the aerodynamic braking system of the rotor of a wind turbine. Active brakes are hydraulic applied and spring released, meaning that the braking force depends on the hydraulic pressure.

DATASHEET SPECIFICATION

ARTICLE NUMBER	20-1526
MAX. PRESSURE	21 MPa
MAX. CLAMPING FORCE	267,1 kN
MAX. BRAKING FORCE	213,7 kN
FRICTION COEFFICIENT μ	0,4 [-]
DISC THICKNESS	30 mm
WEIGHT	60 kg
BRAKE HOUSE MATERIAL	EN-GJS-600-10
TEMPERATURE RANGE	-40 / +70 °C
PISTON DIAMETER	90 mm
SINGLE PISTON SURFACE AREA	63,6 cm ²
LINING TYPE	Organic TR097
LINING DIMENSIONS	215 x 108 mm
LINING THICKNESS	20 mm
FRICTION MATERIAL THICKNESS	10 mm
MAX. PERMITTED LINING WEAR	8 mm

FEATURES

- Several lining materials, including sintered metal and organic
- Spring retracted brake pads
- Optional temperature and / or wear sensors
- Air gap brake pads according to customer specification
- Grooved brake pads for redirecting fine dust & contamination
- Lifting eyes for good handling and fitting
- Drain ports for oil leakage, preventing pads contamination
- Brake pads with electric wear indicators

CALCULATION LEGENDA

- F_b** = Braking Force
- F_c** = Clamping Force
- μ** = Friction Coefficient
- M_b** = braking Torque
- z** = Number of Brakes
- D_{av}** = Effective Diameter of brake



BRAKING FORCE GRAPH

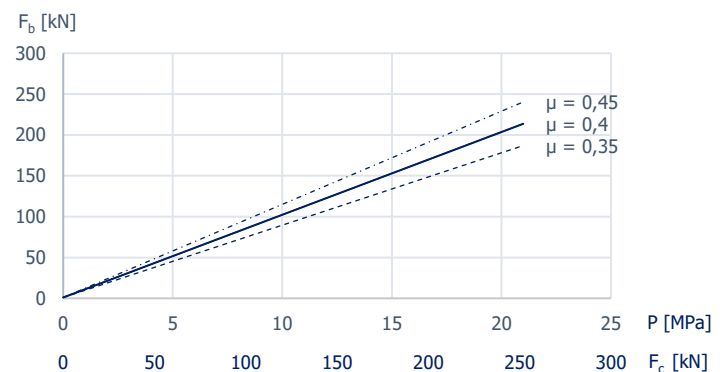

BRAKE FORCE CALCULATION

$$F_b = 2 \cdot F_c \cdot \mu^*$$

$$F_c = A \cdot P \cdot 10 \text{ [N]}$$

$$M_b = z \cdot F_b \cdot \frac{D_{av}}{2}$$

*External factors have not been taken into consideration

GENERAL ARRANGEMENTS

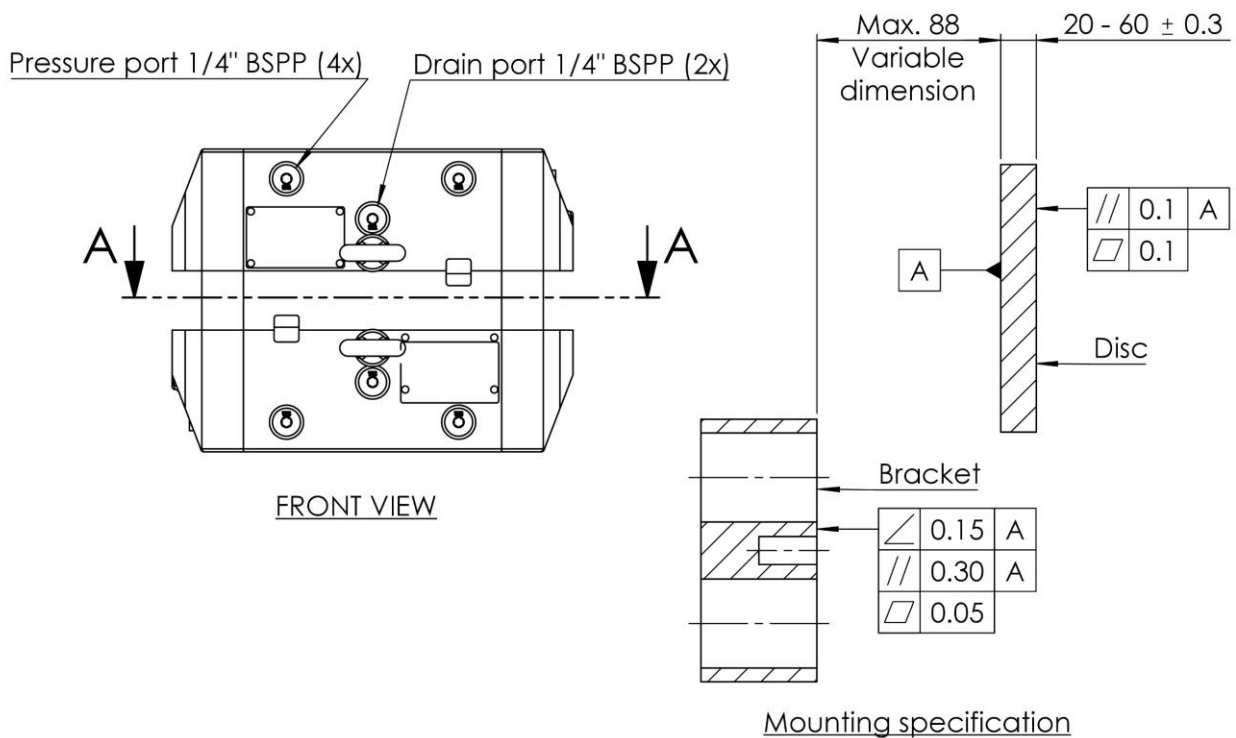
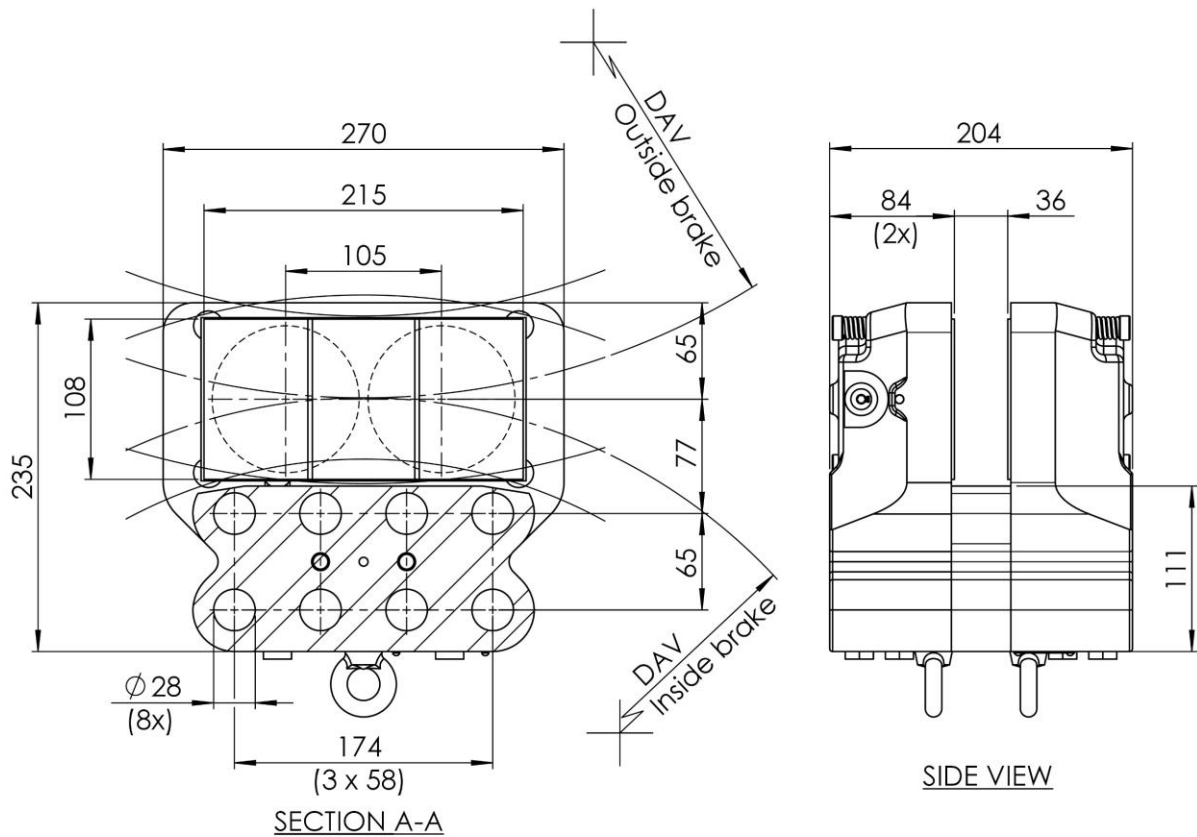

Trebu reserves the rights to modification without prior notification