

AB-3-120-102 ROTOR BRAKE

Active brakes are a complement to the aerodynamic braking system of the rotor of a wind turbine. Active brakes are hydraulic applied and spring released, meaning that the braking force depends on the hydraulic pressure.

DATASHEET SPECIFICATION

ARTICLE NUMBER	20-1316
MAX. PRESSURE	19 MPa
MAX. CLAMPING FORCE	644,7 kN
MAX. BRAKING FORCE	515,8 kN
FRICTION COEFFICIENT μ	0,4 [-]
DISC THICKNESS	20 - 60 mm
WEIGHT	192 kg
BRAKE HOUSE MATERIAL	EN-GJS-500-7
TEMPERATURE RANGE	-40 / +70 °C
PISTON DIAMETER	120 mm
SINGLE PISTON SURFACE AREA	113,1 cm ²
LINING TYPE	Organic TR142
LINING DIMENSIONS	410 x 136 mm
LINING THICKNESS	36 mm
FRICTION MATERIAL THICKNESS	7 mm
MAX. PERMITTED LINING WEAR	3 mm

FEATURES

- Several lining materials, including sintered metal and organic
- Spring retracted brake pads
- Applicable for several disc thicknesses
- Air gap brake pads according to customer specification
- Grooved brake pads for redirecting fine dust & contamination
- Lifting eyes for good handling and fitting
- Drain ports for oil leakage, preventing pads contamination
- Brake pads with electric wear indicators

CALCULATION LEGENDA

- F_b** = Braking Force
- F_c** = Clamping Force
- μ** = Friction Coefficient
- M_b** = braking Torque
- z** = Number of Brakes
- D_{av}** = Effective Diameter of brake



BRAKING FORCE GRAPH

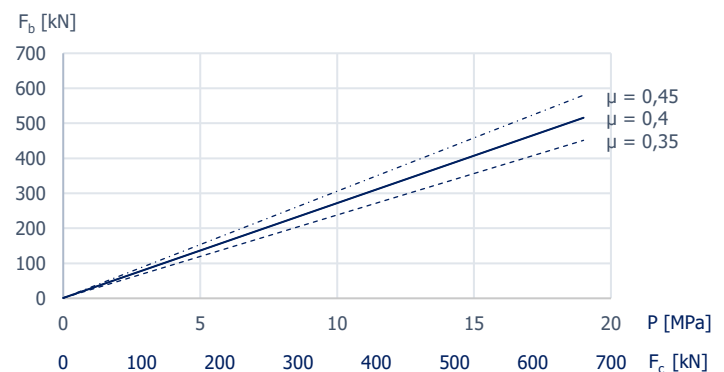

BRAKE FORCE CALCULATION

$$F_b = 2 \cdot F_c \cdot \mu^*$$

$$F_c = A \cdot P \cdot 10 \text{ [N]}$$

$$M_b = z \cdot F_b \cdot \frac{D_{av}}{2}$$

*External factors have not been taken into consideration

GENERAL ARRANGEMENTS

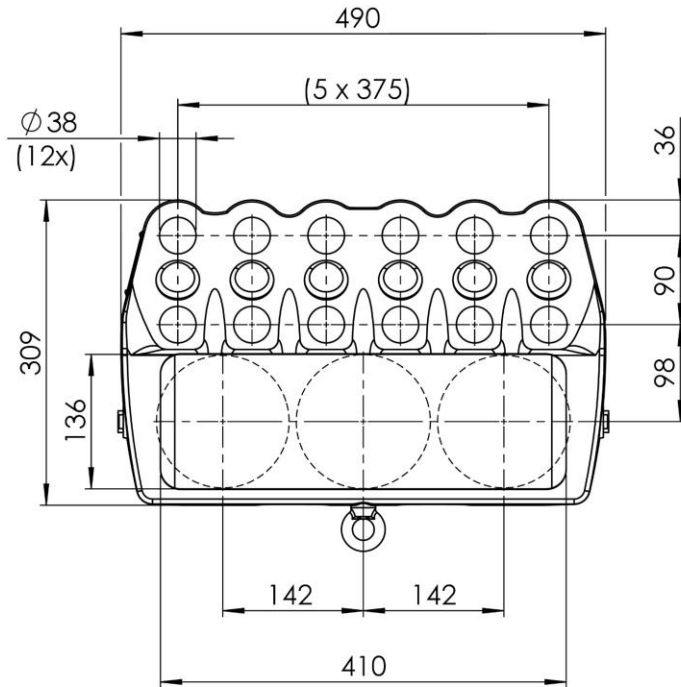

SECTION A-A

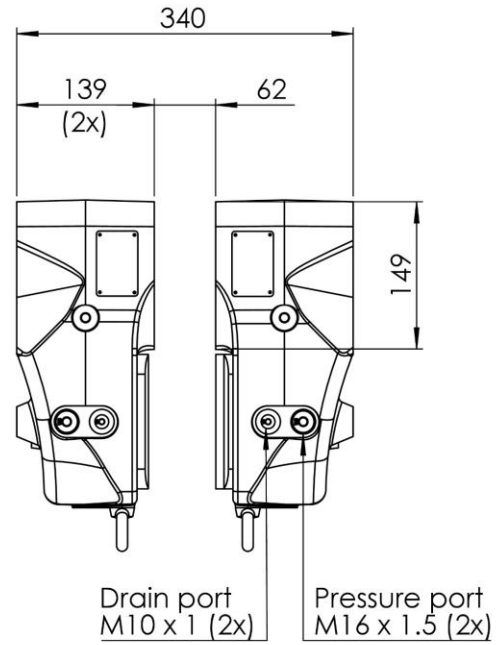

SIDE VIEW

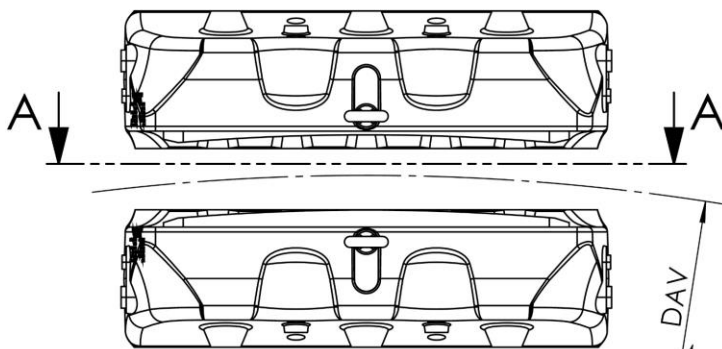

FRONT VIEW

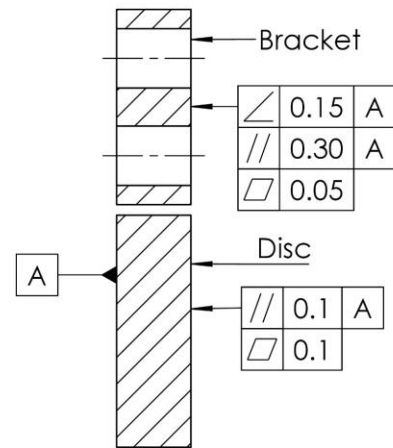

Mounting specification

Trebu reserves the rights to modification without prior notification